

# DISPLAY | Espositori da banco

ESPOSITORI REFRIGERATI DA BANCO

## RC 100W

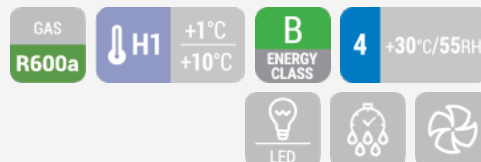

### DETTAGLI



Vetri laterali e frontale curvi



Basamento in acciaio inox con controllore digitale



Luce LED interna



Porte scorrevoli posteriori



### CARATTERISTICHE GENERALI

Espositore refrigerato da banco 120 Lt. BIANCO	•
Vetro curvo con cornice bianca e basamento in acciaio inox	•
Refrigerazione Ventilata	•
Sbrinamento automatico a fermata compressore	•
Controllo con display digitale	•
Luce interna LED	•
Doppio vetro anti-condensazione	•
Porte scorrevoli posteriori	•
Ripiani regolabili cromati (N.2 Pcs)	•
N.4 supporti fissi assemblati sotto il basamento	•
Classe energetica: B	•

### SPECIFICHE TECNICHE

Capacità	100 L
Temperatura	H1 (+1°C-+10°C)
Consumo	2.498 kWh/24h
Potenza Nominale	160 W
Rumorosità	51 dB(A)
Peso Netto	39.1 Kg
Peso Lordo	47 Kg
Dimensioni Esterne (LxPxH mm)	682x450x675
Dimensioni Interne (LxPxH mm)	622x410x417
Dimensioni Imballo (LxPxH mm)	756x524x880
Quantità di carico 20'/40'/40'HQ	99/204/204

### CERTIFICAZIONI

CE  RoHS

### INGOMBRO PRODOTTO

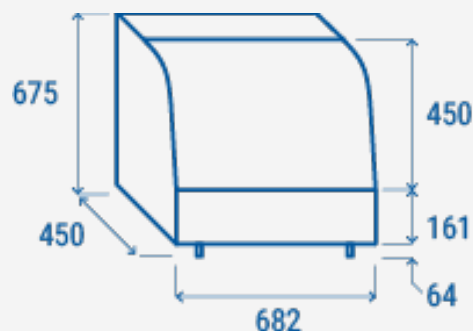

**COOL HEAD EUROPE**  
We make the world a cooler place



[www.coolheadeurope.com](http://www.coolheadeurope.com)